

# Module 3.2

## Resistance of air layers and surface layers

# Learning Outcomes

- On successful completion of this module learners will be able to
  - Describe the concept of resistance of surface layers.
  - Describe the concept of resistance of air layers.

# How insulation works.

- Heat flows naturally from a warmer to a cooler space.
- In winter, the heat moves directly from all heated living spaces to the outdoors and to adjacent unheated attics, garages, and basements - wherever there is a difference in temperature. Source: [http://www.ornl.gov/sci/roofs+walls/insulation/ins\\_01.html](http://www.ornl.gov/sci/roofs+walls/insulation/ins_01.html)

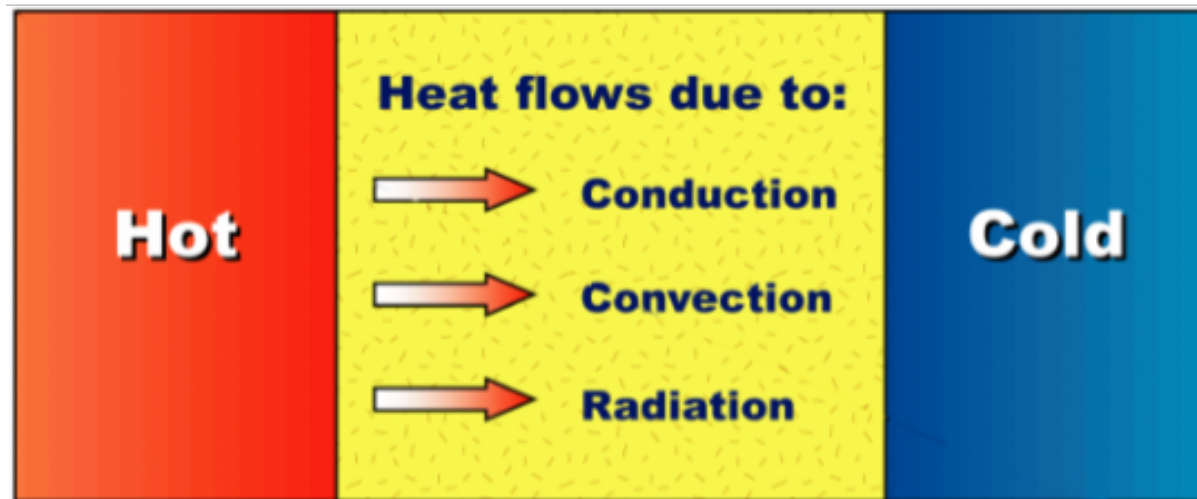

# Forward.

- This document uses extracts from, and makes references to, EN ISO 6946 : 2007

Building components and building elements -  
 Thermal resistance and thermal transmittance -  
 Calculation method.

- The content of this document is not a substitute for the standard. To properly apply the standard one must have the complete document.
- Standards available from [www.iso.org](http://www.iso.org).

# Introduction to resistance of surface layers.

- Most insulation materials work by limiting air movement.
- Heat transfer can occur due to any combination of conduction, convection and/or radiation.
- Heat transfer at the boundary between structural elements and air becomes more complex than heat transfer through solid materials.
- Such boundaries occur for example where the warm air meets the internal surface of the external wall, or where the cold air meets the external surface of the external walls.

- continued.

- This complex heat transfer process at surfaces is recognised as a resistance to heat flow and have been labelled as internal surface resistance  $R_{si}$  and external surface resistance  $R_{se}$ .

# Values of surface resistance.

Surface resistance values for normal (high) emissivity materials are given in Table 1 of EN ISO 6946 : 2007 Building components and building elements - Thermal resistance and thermal transmittance - Calculation method.

<u>Surface Resistance</u>	<u>Direction of heat flow</u>		
	Upwards	Horizontal	Downwards
(m <sup>2</sup> K / W)			
R <sub>si</sub>	0.10	0.13	0.17
R <sub>se</sub>	0.04	0.04	0.04

# Graphical representation of surface resistance layers

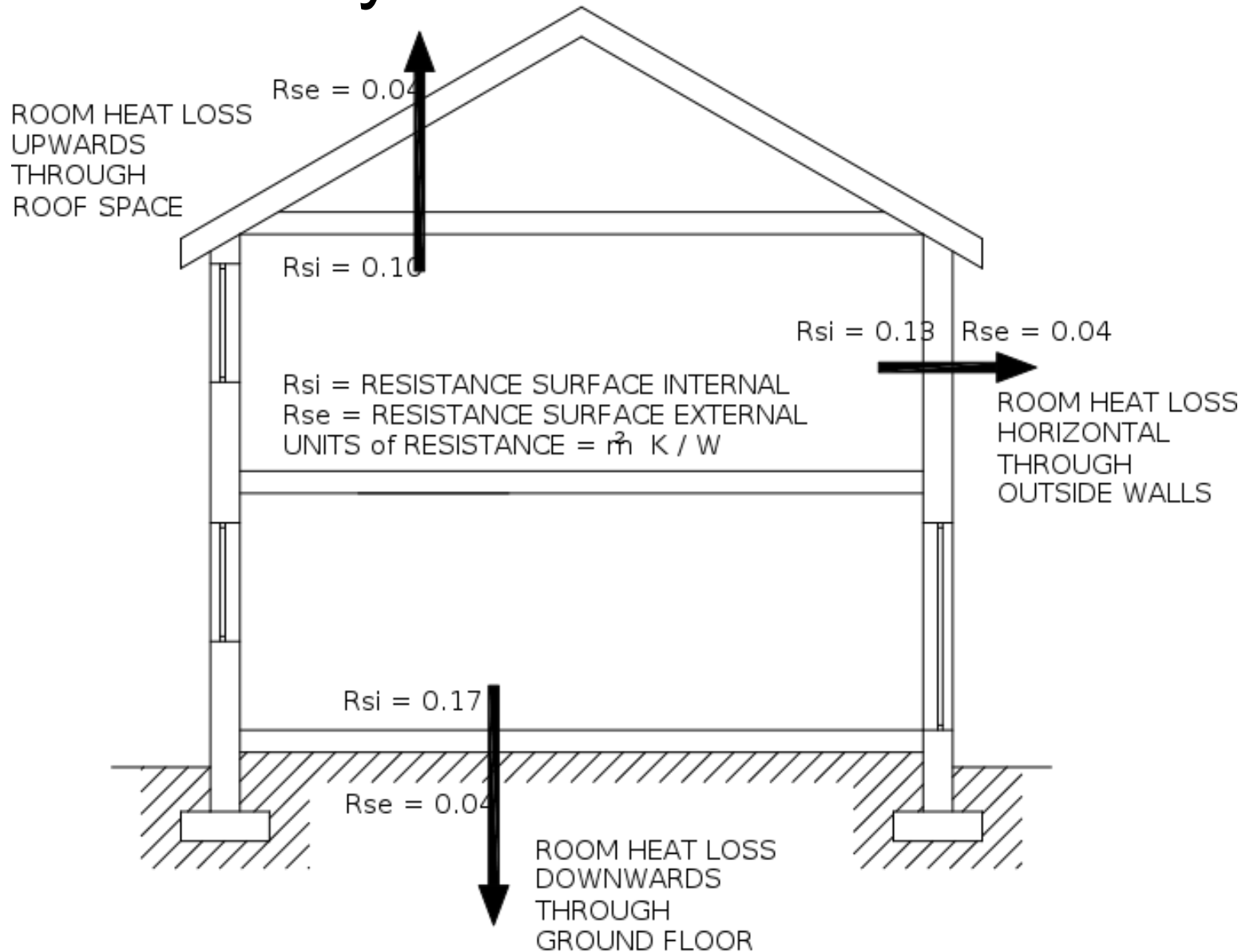

# When to use surface resistance values.

- Surface resistance values in Table 1 can be used for plane surfaces where no specific information is available on the boundary conditions. Otherwise see procedures in EN ISO 6946 Annex A.
- The surface resistances apply to surfaces in contact with air. No surface resistance applies to surfaces in contact with another material.
- EN ISO 6946 and BRE 443 consider “horizontal” as applying to heat flow directions  $\pm 30^\circ$  from the horizontal.
- For a roof having a roof pitch greater than  $60^\circ$  heat flow is considered horizontal.
- For a roof having a roof pitch less than  $60^\circ$  heat flow is considered upwards

# Introduction to resistance ( $R_a$ ) of air layers.

- EN ISO 6946 : 2007

Building components and building elements -  
 Thermal resistance and thermal transmittance -  
 Calculation method,  
 describes values of thermal resistance ( $R_a$ ) for air  
 layers.

- This standard identifies three distinct air layers
  - a) Unventilated air layers
  - b) Slightly ventilated air layers
  - c) Well ventilated air layers.

# General conditions to define any air layer

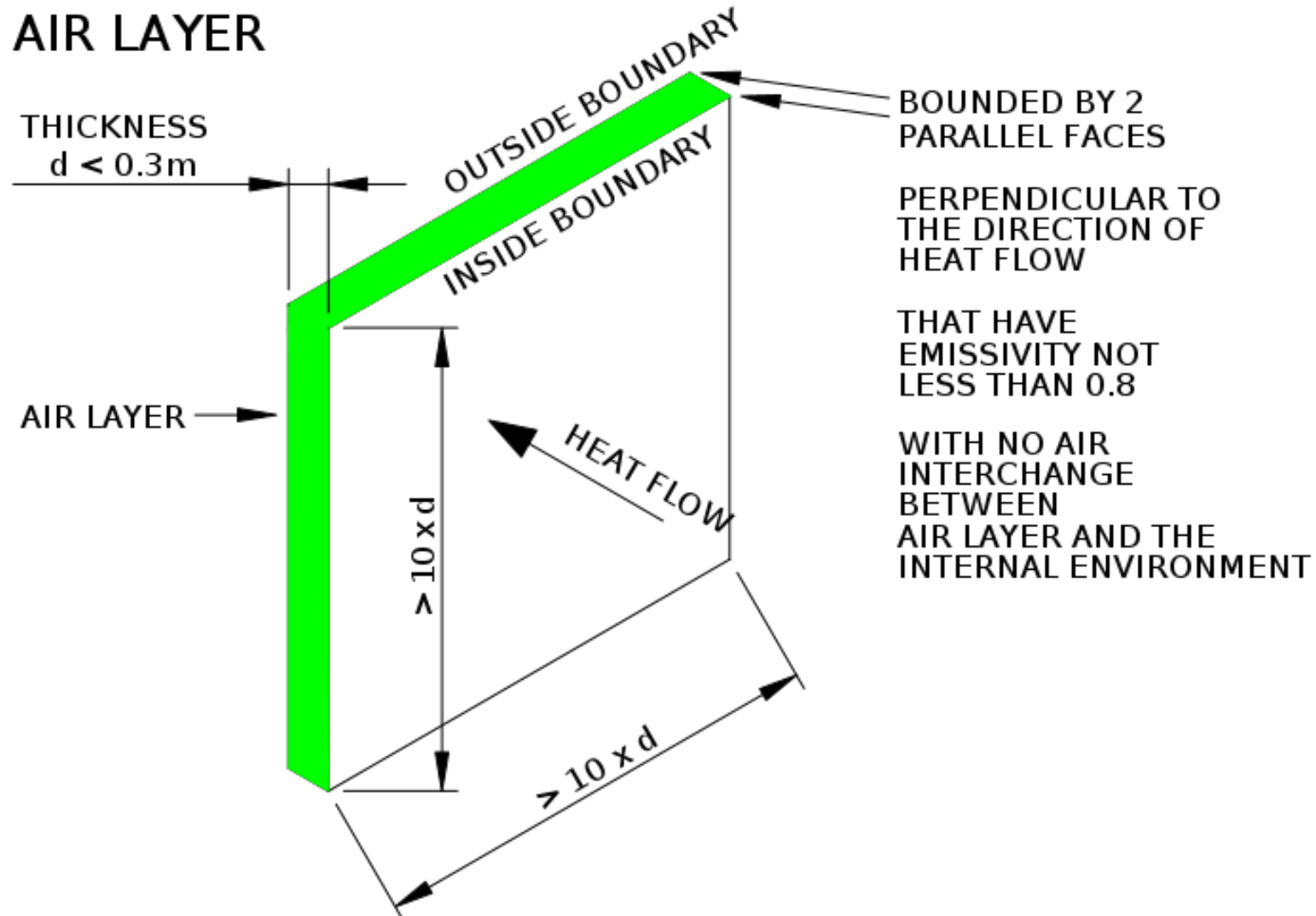

- continued.

- If the air layer does not meet all of the criteria then see alternative procedures in EN ISO 6946.
- NOTE from EN ISO 6946 -  
most building materials have an emissivity greater than 0,8.

.

# Thermal resistance ( $R_a$ ) for unventilated air layers

- In addition to the general conditions for all air layers, EN ISO 6946 describe an unventilated air layer as one where the construction allows little or no air movement through the layer.

More precisely -

1. The construction does not allow any air movement through the air layer.

OR.

- continued.

1. If there are small openings to the external air,
  - i) there should be no insulation between the air gap and the external air,
  - ii) and the openings are not arranged to permit air flow through the layer
  - iii) and the openings do not exceed
    - $500\text{mm}^2$  per m of length (in the horizontal direction) for vertical air layers
    - $500\text{mm}^2$  per  $\text{m}^2$  of surface area for horizontal air layers

- continued.

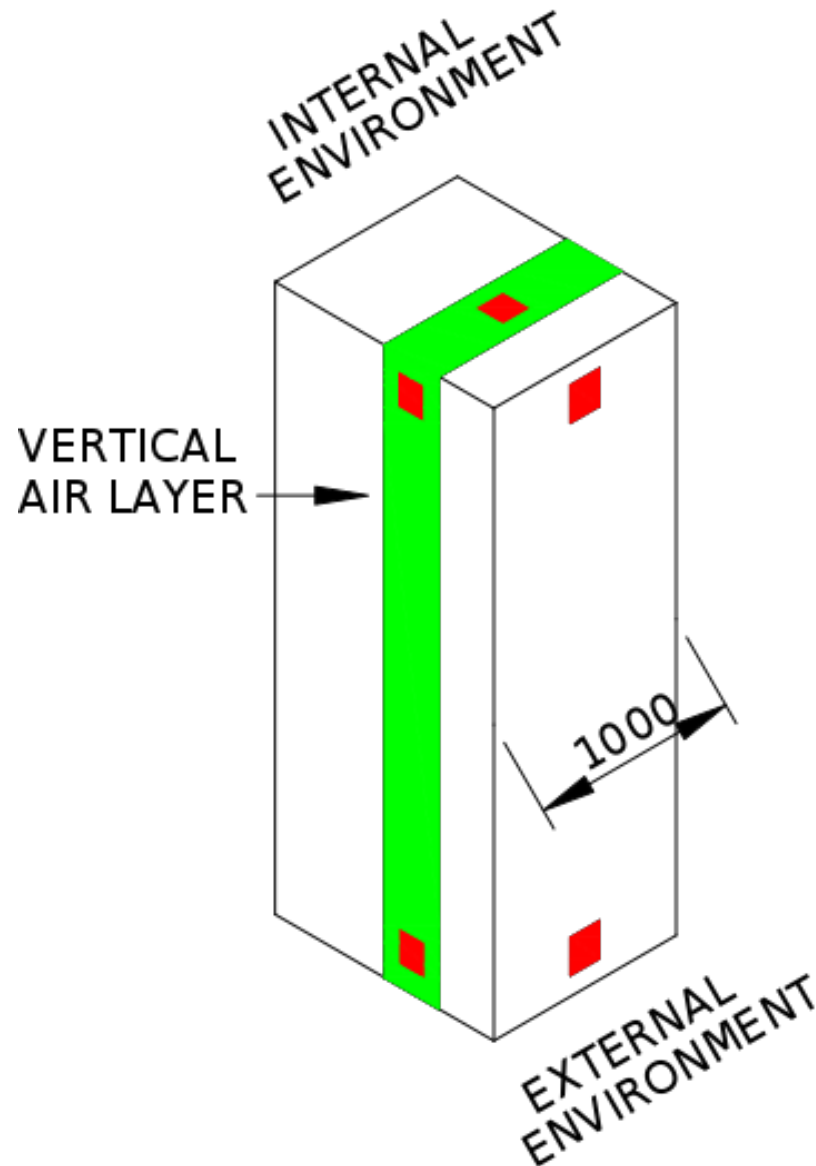

## UN-VENTILATED VERTICAL AIR LAYER

In this example vents are installed at low level and at high level to allow a stack ventilation effect.

■ Possible locations of ventilation openings.

### VENTILATION OPENINGS

A. NONE

OR

B. Total  $< 500\text{m}^2\text{m}$  per metre of length (in the horizontal direction) for vertical air layers.

i.e.  $< 250\text{m}^2\text{m}$  per metre of length at low level plus  $< 250\text{m}^2\text{m}$  per metre of length at high

Equivalent continuous air gap of  $< 0.25\text{mm}$  top and bottom.

- continued.

- Example of an unventilated air layer.

PARTIALLY  
FILLED  
CAVITY

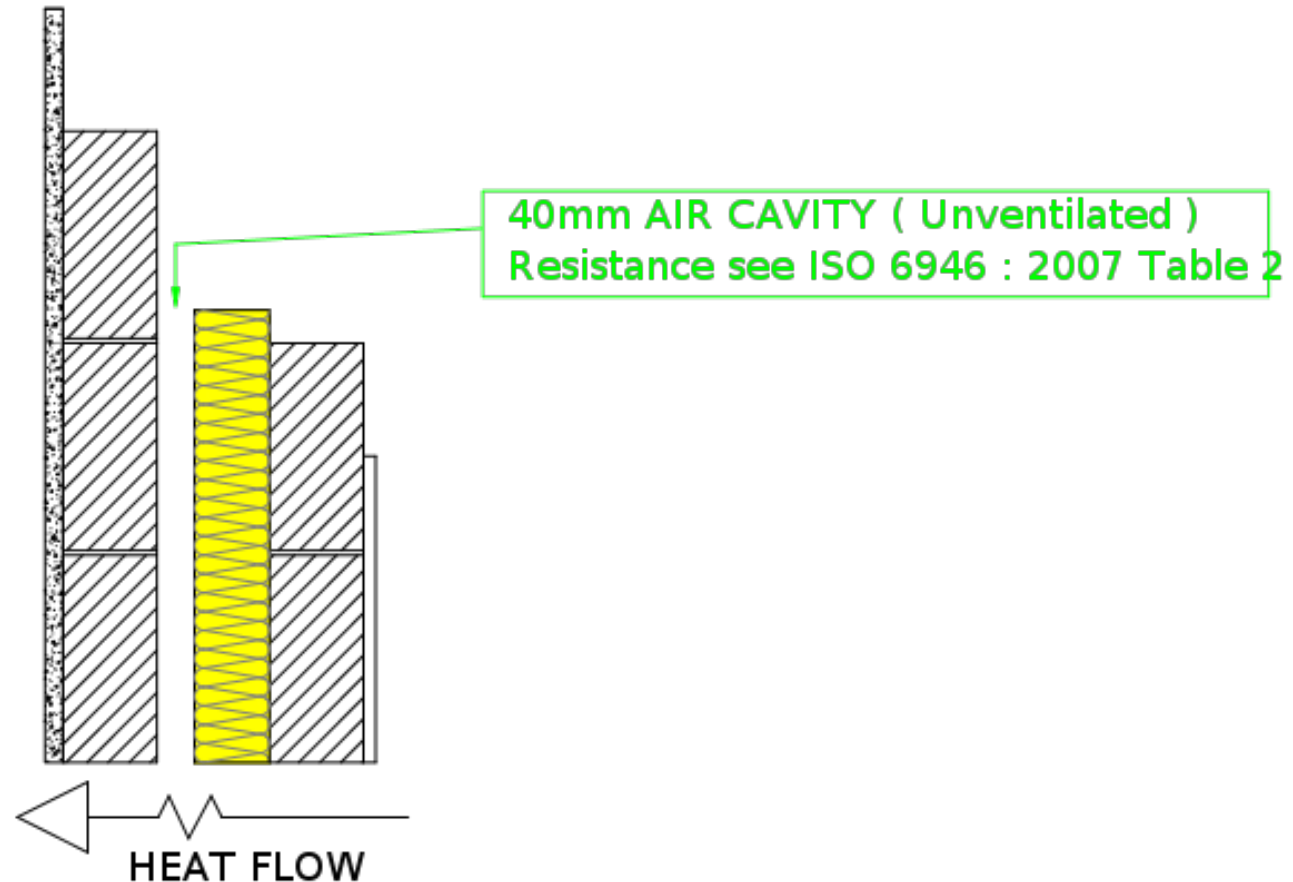

# EN ISO 6946 : 2007 Table 2 – Thermal resistances ( $m^2K/W$ ) of unventilated air layers: high emissivity surfaces.

Thickness of air layer mm	Direction of heat flow		
	Upwards	Horizontal	Downward
0	0.00	0.00	0.00
5	0.11	0.11	0.11
7	0.13	0.13	0.13
10	0.15	0.15	0.15
15	0.16	0.17	0.17
25	0.16	0.18	0.19
50	0.16	0.18	0.21
100	0.16	0.18	0.22
300	0.16	0.18	0.23

# Thermal resistance ( $R_a$ ) for slightly ventilated air layer.

- In addition to the three general conditions for all air layers, EN ISO 6946 defines a slightly ventilated air layer as one in which the construction allows limited air flow through the air layer, from the external environment, by openings of area,  $A_v$ , within the ranges:
  - $>500 \text{ mm}^2$  but  $<1500 \text{ mm}^2$  per metre of length (in the horizontal direction) for vertical air layers
  - $>500 \text{ mm}^2$  but  $<1500 \text{ mm}^2$  per square metre of surface area for horizontal air layers.

- continued.

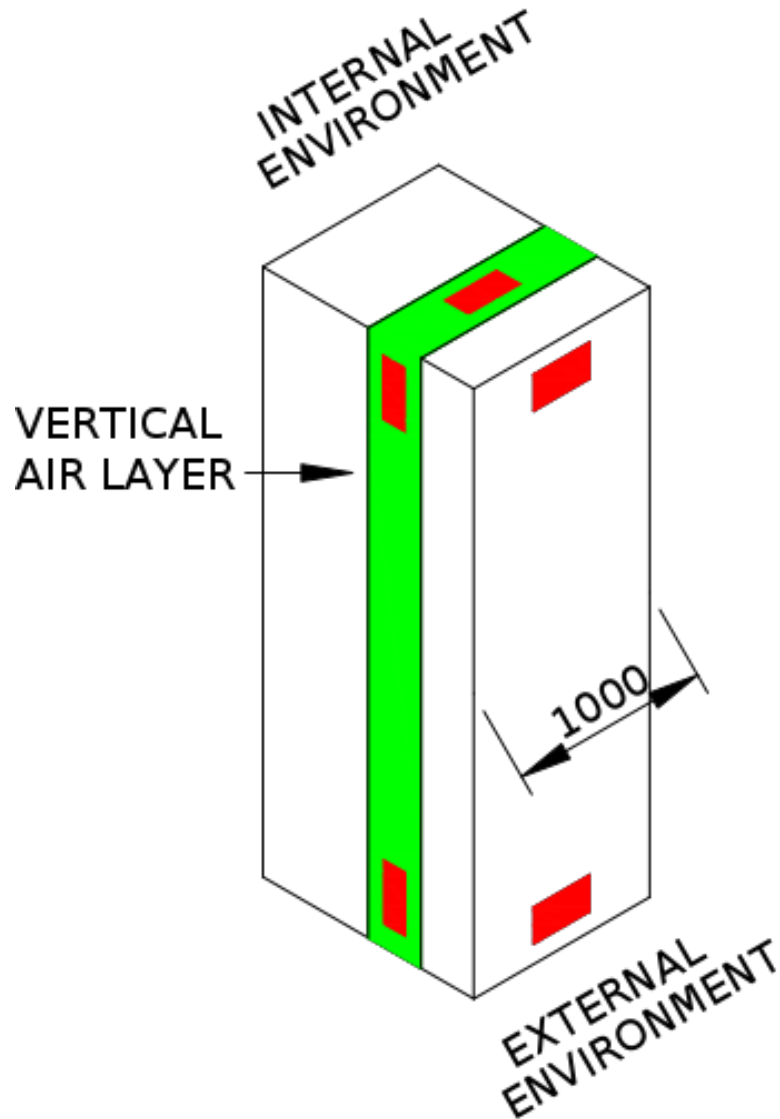

## SLIGHTLY VENTILATED VERTICAL AIR LAYER

In this example vents are installed at low level and at high level to allow a stack ventilation effect.

■ Possible locations of ventilation openings.

### VENTILATION OPENINGS

Total  $>500\text{m}^2\text{m}$  and  $<1500\text{m}^2\text{m}$  per metre of length (in the horizontal direction) for vertical air layers.

i.e. between  $250\text{m}^2\text{m}$  and  $750\text{m}^2\text{m}$  per metre at low level plus between  $250\text{m}^2\text{m}$  and  $750\text{m}^2\text{m}$  per metre at high level

Equivalent continuous air gap of 0.25mm to 0.75mm top and bottom.

- continued.

- The effect of ventilation depends on the size and distribution of the ventilation openings  $A_v$ .
- EN ISO 6946 approximates the total thermal resistance  $R_T$  of a construction with a slightly ventilated air layer may be calculated as

$$R_T \approx \frac{1500 \square A_v}{1000} R_{T,u} \approx \frac{A_v \square 500}{1000} R_{T,v}$$

- $R_{T,u}$  is the total thermal resistance with an unventilated air layer.
- $R_{T,v}$  is the total thermal resistance with a well ventilated air layer.

# Thermal resistance ( $R_a$ ) for well ventilated air layer.

- In addition to the three general conditions for all air layers, I.S. EN ISO 6946 defines a well ventilated air layer as one for which the openings between the air layer and the external environment are
  - $\geq 1500 \text{ mm}^2$  per metre of length (in the horizontal direction) for vertical air layers,
  - $\geq 1500 \text{ mm}^2$  per square of metre of surface area for horizontal air layers.

- continued.

## WELL VENTILATED VERTICAL AIR LAYER

In this example vents are installed at low level and at high level to allow a stack ventilation effect.

■ Possible locations of ventilation opening

### VENTILATION OPENINGS

Total  $> 1500\text{m}^2\text{m}$  per metre of length (in the horizontal direction) for vertical air layers.

i.e.  $> 750\text{m}^2\text{m}$  per metre of length at low level plus  $> 750\text{m}^2\text{m}$  per metre of length at high

Equivalent continuous air gap of  $> 0.75\text{mm}$  top and bottom.

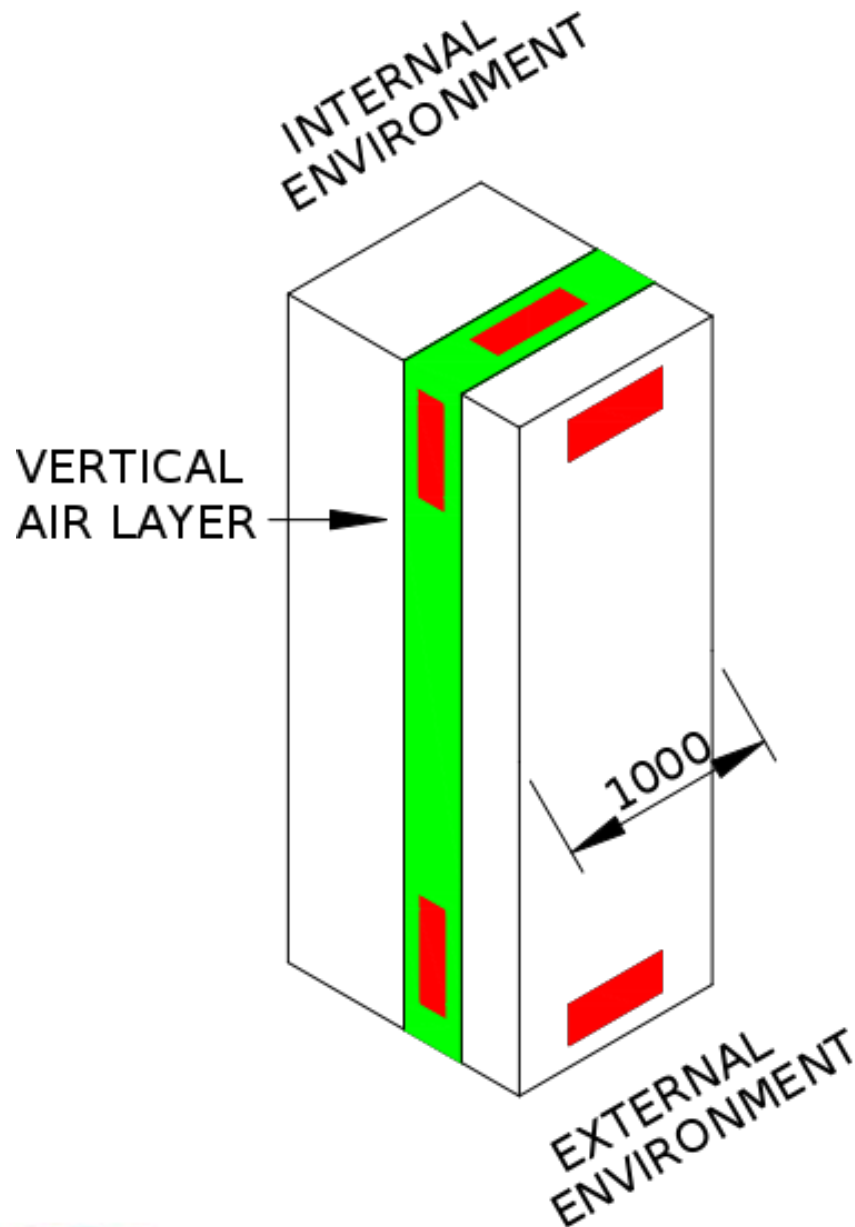

- continued.

- The total thermal resistance of a building component containing a well-ventilated air layer shall be obtained by disregarding the thermal resistance of the air layer and all other layers between the air layer and external environment, and including an external surface resistance corresponding to still air (see EN ISO 6946: 2007 Annex A).
- Alternatively, the corresponding value of  $R_{si}$  may be used. (see EN ISO 6946: 2007 Table 1).

# Module summary

- Solid building materials provide a resistance to heat transfer by limiting conduction, convection and/or radiation.
- Heat transfer at the boundary between solid elements and air becomes more complex than heat transfer through solid materials.
- These boundary resistance layers have been given names.
- Task.

List the names of these two surface resistance layers.

## Module summary – continued.

- The actual value of these resistance layers can vary depending on the direction of heat flow.
- Tasks.
  - a) State the values for horizontal air flow.
  - b) State the values for upward heat flow.
    1. State the values for downward heat flow.
    2. State the units for these values.

# Module summary – continued.

EN ISO 6946 identifies three different types of air layers.

- Tasks.

List the names of these 3 different types of air layer.

For each layer describe the size of any ventilation openings allowed.

Identify possible construction details that would provide examples of each type of air layer.

# Acknowledgements:

- The authors and publishers of this document wish to thank the National Standards Authority of Ireland for permission to reproduce extracts from copyright material EN ISO 6946 : 2007 Building components and building elements - Thermal resistance and thermal transmittance - Calculation method.

# References.

- International standards.

- EN ISO 6946 : 2007

Building components and building elements -  
Thermal resistance and thermal transmittance -  
Calculation method.

- National standards.

- BRE 443 : 2006 – Convention for U-value calculations. ISBN 1 86081 924 9